



# NetRiver selects energy efficient, scalable, compact UPS and Power Xpert™ monitoring

Case Study – Gartner Datacenter Conference, Dec. 2<sup>nd</sup>, 2008. Las Vegas, NV

Alan R Chiste  
Eaton Corp  
[Alanrchiste@eaton.com](mailto:Alanrchiste@eaton.com)

Adam Vierra  
NetRiver  
[Adam.Vierra@NetRiver.net](mailto:Adam.Vierra@NetRiver.net)

# Agenda

---

- Overview
- The site parameters
- Proposal
  - Feature/benefit
- Installation
- Feedback
- Conclusion

# Overview - NetRiver



- NetRiver is a high density co-location provider in Lynnwood, WA
- High availability, high efficiency solutions for their clients.
- Large expansion utilizing Powerware's 9395 modular UPS that offers high efficiency across the load spectrum, scalable and reduced footprint
- This presentation will discuss the technical review process, selection and topology of the complete system: Monitoring for the UPS systems, Maintenance Bypass Cabinets, PDUs and RPPS using the Power Xpert architecture for end-to-end reliability.

# Expansion Criteria

---

- New load, estimated at 1.5MW UPS Power required
- UPS, Battery and PDU/RPP to fit in extremely tight space
- Scalability – Add UPS modules in future if needed
- Redundancy – N+1 now or in the future
- “Green” – High efficiency design
  - PUD monetary rebates
- End to end monitoring and diagnostics
- Delivery and Completion 2008

# Expansion one line

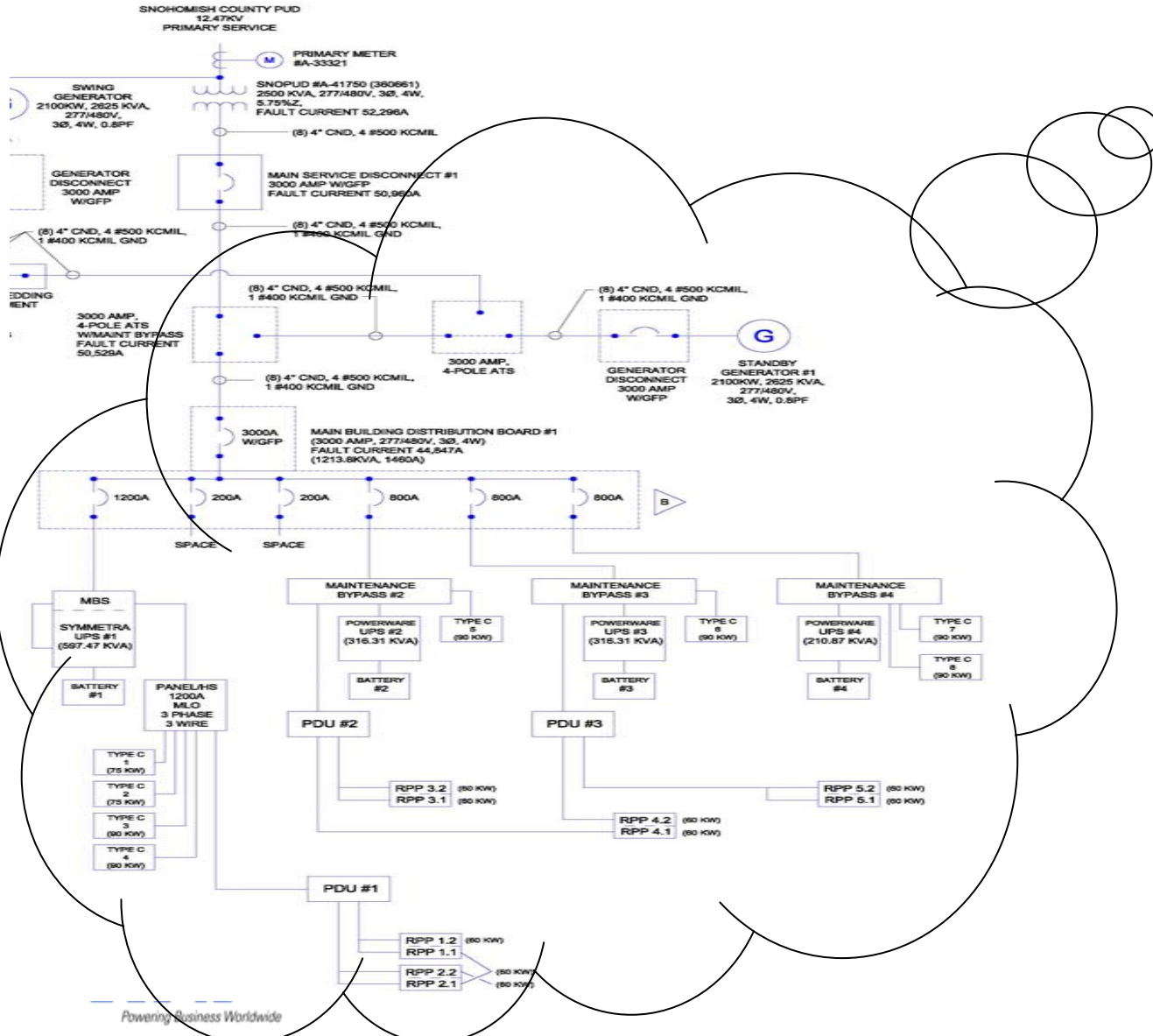

Site expansion:  
1.5MW of UPS and  
associated distribution  
equipment

# Site Parameters Requirements

---

- Extremely tight UPS/Battery/Distribution floor space
  - Available UPS room dimensions were 16 feet by 31 feet
- 480V/208V conversion at PDU level in UPS location
- In-Row high density RPP distribution required
  - 4 x 42 cct, branch circuits in 24"x24" space
  - Branch cct monitoring/web enabled
- Build out to utilize “green” approach – PUD assessment for energy rebates
- UPS energy efficiency given high marks for consideration
- Time line – first 2 PDU’s required on site in 4 weeks

# Site Parameters – UPS Footprint/Highest Power Density

- 550kVA Modules
- ISBM – integrated system bypass (with sts)
- UPM1/2 – fully rated 275kva UPS system
- .9 pf leading/lagging
- Inherent redundancy
- Transformerless technology
- 94.6% efficiency in RT mode, 99% in HE mode



# Site Parameters – UPS Footprint/Highest Power Density

| Manufacturer   | kVA | Density<br>(kW<br>per ft <sup>2</sup> ) | Weight | Footprint<br>(ft <sup>2</sup> ) | Dimensions<br>(HxWxD, in.) | Cross Country<br>Freight Cost |
|----------------|-----|---|--------|---------------------------------|----------------------------|-------------------------------|
| Powerware 9395 | 550 | 29.6                                    | 2977   | 16.7                            | 73.6x32.7x73.7             | \$893                         |
| Competitor A   | 500 | 24.1                                    | 6900   | 18.7                            | 69.0x39.0x82.0             | \$2,070                       |
| Competitor B   | 500 | 24.0                                    | 5226   | 18.8                            | 80.7x33.5x76.7             | \$1,568                       |
| Competitor C   | 500 | 23.9                                    | 5512   | 20.9                            | 94.0x32.0x71.0             | \$1,654                       |
| Competitor D   | 500 | 23.1                                    | 5795   | 19.5                            | 72.0x39.0x78.0             | \$1,739                       |
| Competitor E   | 600 | 20.6                                    | 6373   | 29.1                            | 99.8x42.0x80.0             | \$1,912                       |
| Competitor F   | 500 | 15.1                                    | 6930   | 29.9                            | 114.2x37.7x79.7            | \$2,079                       |

- ✓ Space savings, valued at over \$1500 per square foot
- ✓ Freight Savings: Half the freight cost
- ✓ Fits through all doors, freight elevators, no dismantling, no need for crane rental
- ✓ Easier handling/Installation

# Site Parameters - 3 x 500kW Layout

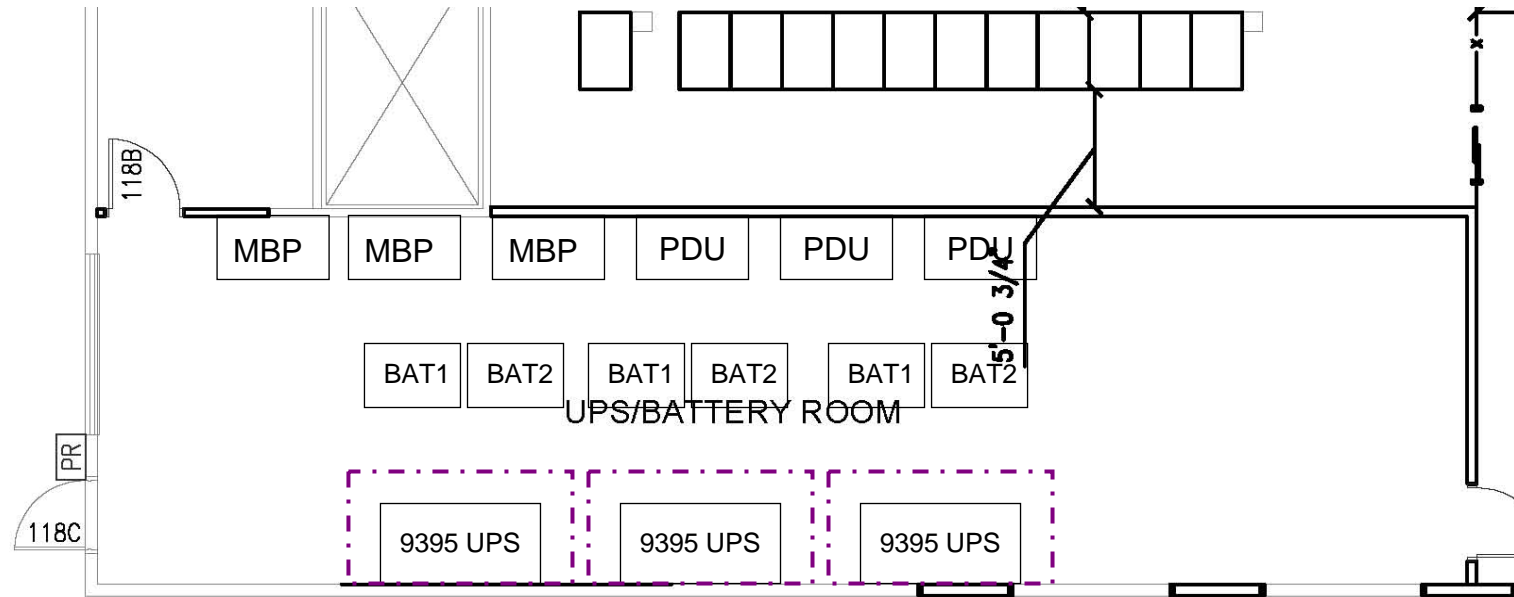

Eaton UPS Total Footprint, 50.1 ft<sup>2</sup>  
Competitor Total Footprint, 87.5 ft<sup>2</sup>

Total Weight: 8931 lb  
Total weight 21,120 lbs

- At \$1500/ft<sup>2</sup>, the space savings is approx. \$57K
- At \$.30 per lb, cross-country freight savings is approx. \$3.7K

# Site Parameters – 16V Front Terminal Design Battery System

- 16v battery allows fewer cell to get DC bus voltage
- Smaller footprint, cabinet is 84”h
- Simplified maintenance
- Simplified installation
- Simplified replacement
- Fewer connections
  - 30 units in typical 480V system
  - Solid busbar connections
- 2 strings provide 8 min runtime at 500kw



# Feature/Benefit - Redundancy

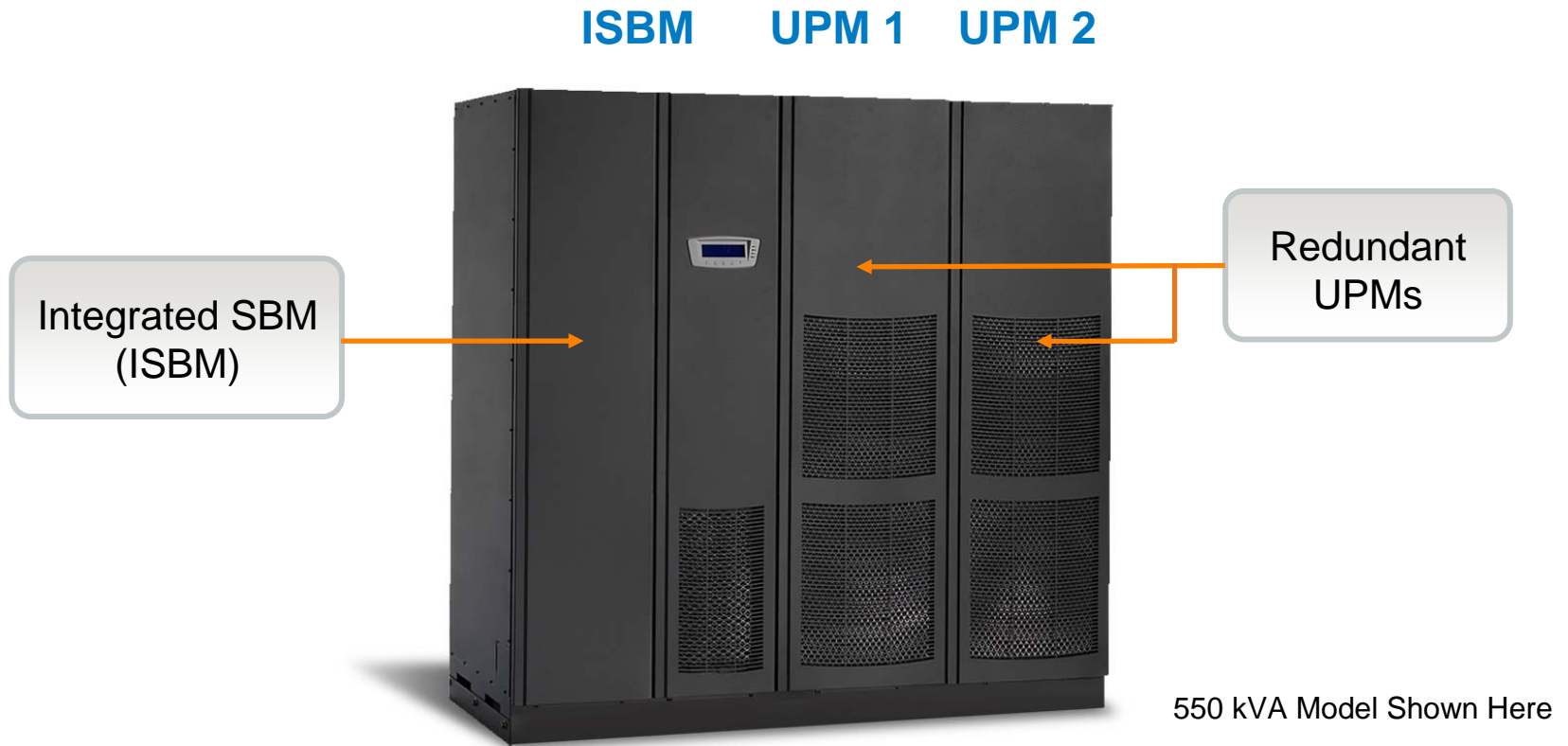

**New design enables highest reliability**

# Feature/Benefit - Flexible, Scalable, Upgradeable

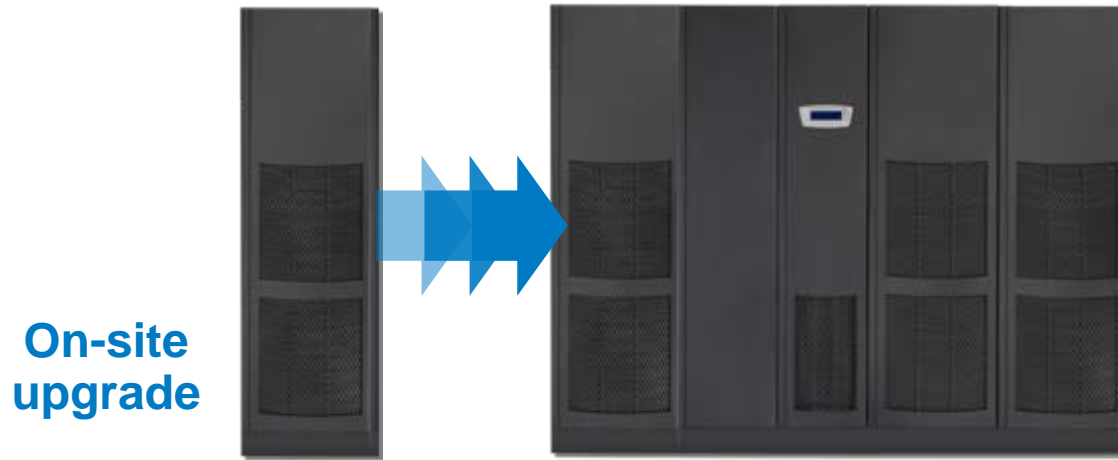

550 kVA Redundant!

- NetRiver utilized the 550kVA which is future upgradable to N+1 design
  - Simply choose an ISBM sized for future growth
  - Leave space on the left side
- Enables flexibility for future changes in load demands, and new requirements for higher reliability

# Feature/Benefit – High-efficiency Multi-mode UPS

High-efficiency Multi-mode UPS products will start making their way into medium and large data centers

Multi-module systems in MVA applications will be no exception

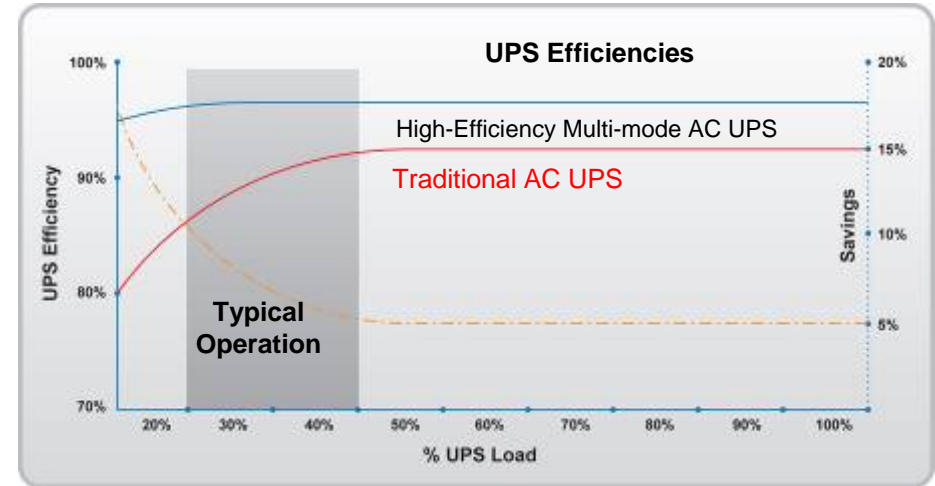
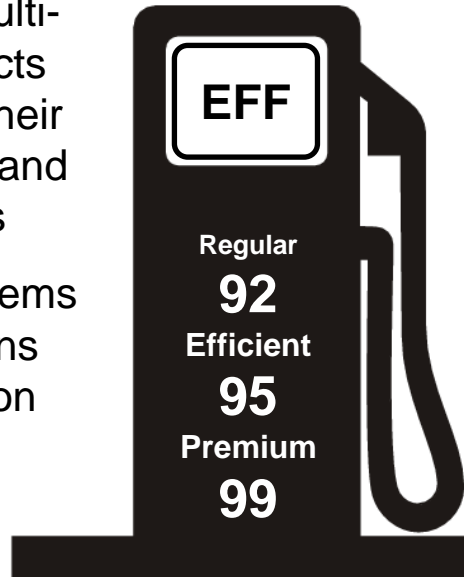

- Highly efficient during normal AC power, instantly converts to double conversion with poor power quality
- Flat energy conversion efficiency over wide load range.
- Improved efficiency of 6% to 15% across full load range over traditional legacy UPS.

# Feature/Benefit – Energy savings on HE Mode

1. Enter Data

|         |                           |
|---------|---------------------------|
| 60%     | DCiE (0-100%)             |
| 500     | kW (UPS rating)           |
| \$0.07  | \$/kWh                    |
| \$12.00 | \$/kW                     |
| 8760    | hrs/yr operation          |
| 3%      | discount rate             |
| 10      | project life (max 20 yrs) |

**Results:**

UPS 1 uses **21.77** kW **less** kW than UPS 2 or **4.35%** (% of FL)

UPS 1 has **489%** **lower** losses than UPS 2

When including cooling costs **36.28** kW extra energy is wasted

Savings: **\$27,474.16** and **381,416** lbs/CO2 per year  
**\$234,360.16** and **3,814,162** lbs/CO2 over project life (discounted)

2. Enter Efficiency and Loading Data

| % Time at Load                       | This Load | UPS 1        |                                |        | Weighted Losses              | UPS 2      |         |                               | Weighted Losses |
|--------------------------------------|-----------|--------------|--------------------------------|--------|------------------------------|------------|---------|-------------------------------|-----------------|
|                                      |           | Efficiency   | kW Load                        | Losses |                              | Efficiency | kW Load | Losses                        |                 |
| 0%                                   | 0         | 0            | 0                              | 5.0    | 0.00                         | 0          | 10.0    | 0.00                          |                 |
| 10%                                  | 0         | 0            | 50                             | 0.5    | 0.00                         | 80.90%     | 50      | 9.5                           | 0.00            |
| 20%                                  | 0%        | 0            | 100                            | 1.0    | 0.00                         | 88.43%     | 100     | 11.6                          | 0.00            |
| 30%                                  | 0%        | 0            | 150                            | 1.5    | 0.00                         | 90.90%     | 150     | 13.6                          | 0.00            |
| 40%                                  | 0%        | 0            | 200                            | 2.0    | 0.00                         | 92.57%     | 200     | 14.9                          | 0.00            |
| 50%                                  | 0%        | 0            | 250                            | 2.5    | 0.00                         | 93.20%     | 250     | 17.0                          | 0.00            |
| 60%                                  | 0%        | 0            | 300                            | 3.0    | 0.00                         | 93.84%     | 300     | 18.5                          | 0.00            |
| 70%                                  | 0%        | 0            | 350                            | 3.5    | 0.00                         | 93.85%     | 350     | 21.5                          | 0.00            |
| 80%                                  | 10%       | 0.08         | 400                            | 4.0    | 0.40                         | 94.09%     | 400     | 23.6                          | 2.36            |
| 90%                                  | 90%       | 0.81         | 450                            | 4.5    | 4.05                         | 94.11%     | 450     | 26.5                          | 23.86           |
| 100%                                 | 0%        | 0            | 500                            | 5.0    | 0.00                         | 94.21%     | 500     | 28.9                          | 0.00            |
| <b>100%</b><br>(sum must equal 100%) |           | <b>89.0%</b> | <b>Ave Load</b><br>445 kW Load |        | <b>4.45 kW</b><br>Ave Losses |            |         | <b>26.22 kW</b><br>Ave Losses |                 |

**\$27K per year in savings!!**

3. Choose State

| Electrical Savings     |                      |                    |                           |
|------------------------|----------------------|--------------------|---------------------------|
| Electrical Savings     | Monthly Savings      | Annual Savings     | Savings per...            |
| 36.28 kW               | \$435.41 \$/kW/mo    | \$5,224.88         | \$/yr (kW demand savings) |
| 317846.86 kWh/yr saved | \$1,854.11 \$/kWh/mo | \$22,249.28        | \$/yr (kWh savings)       |
|                        |                      | <b>\$27,474.16</b> | \$/yr (total savings)     |
|                        |                      |                    | <b>\$99.91</b> \$/UPS kW  |

| Greenhouse Gas Savings                                       |                            |                 |                        |
|--|----------------------------|-----------------|------------------------|
| Choose State   | Annual GHG Savings         | based on        | Savings per...         |
| Choose State: <input type="text" value="WA"/>                | CO2 <b>381416.2</b> lbs/yr | 1.2 lbs/kWh/yr  | <b>762.8</b> lbs/yr/kW |
| EPA Region: 10   | SO2 <b>158.9</b> kg/yr     | 0.5 g/kWh/yr/yr | <b>0.3</b> g/yr/kW     |
| (different regions generate different GHG per kWh generated) | NOx <b>95.4</b> kg/yr      | 0.3 g/kWh/yr/yr | <b>0.2</b> g/yr/kW     |

# Feature/Benefit – High-efficiency Multi-mode UPS

The 9395 high efficiency UPS will have three configurable modes of operation: Standard, High Alert, and High Efficiency mode. All modes will be selectable from the front panel, signal inputs, or thru serial communications (XCP).

## 1: Standard Mode, Double conversion

In standard mode the unit operates as a traditional online UPS by supplying power thru the power converters (Rectifier and Inverter).

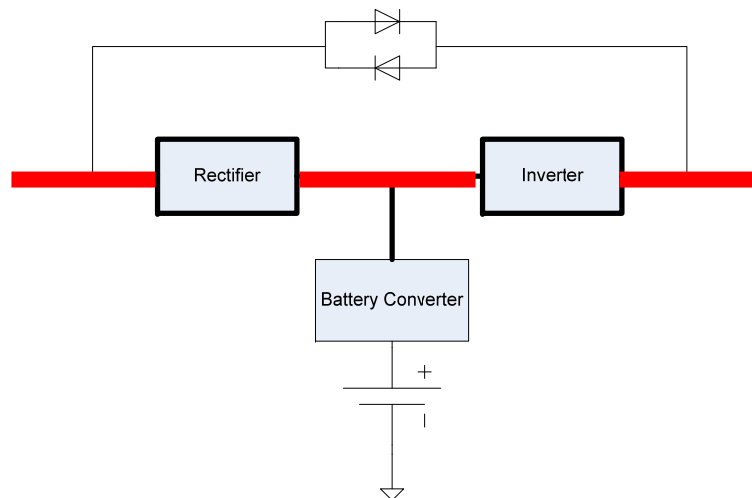

# Feature/Benefit – High-efficiency Multi-mode UPS

## 2: High Efficiency Mode

In high efficiency mode the load is supported from the bypass. All power converters are off and are in the ready state (in case a forward transfer is needed). During this mode, the output contactor is closed and the link is maintained thru the diode bridge. If the utility exceed the output rating the unit will transfer to standard mode of operation until the utility returns within limits.

Output regulation online (voltage / frequency) will match utility when transitioning between HE mode and online mode.

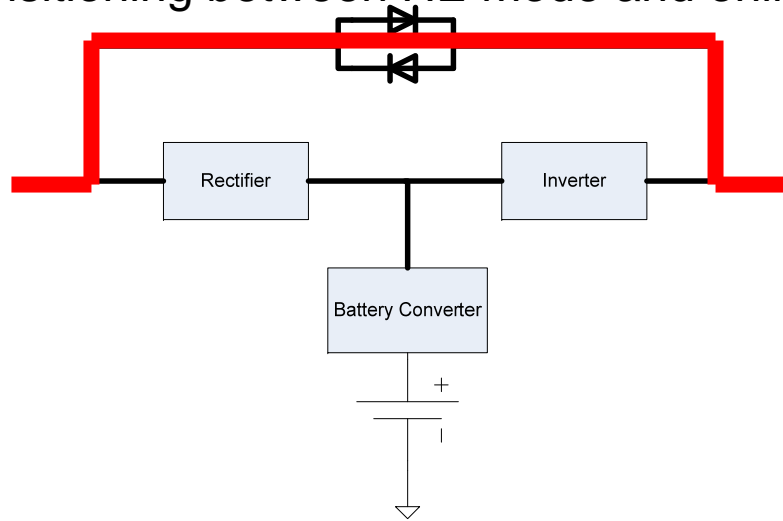

# Feature/Benefit – High-efficiency Multi-mode UPS

## 3: High Alert Mode

In high alert mode the unit transfers from high efficiency mode to online (standard) mode for one hour (*EEP configurable*). At the completion of the hour, the unit defaults back to high efficiency mode. If the high alert command is received during the one hour, the one hour timer will be restarted.

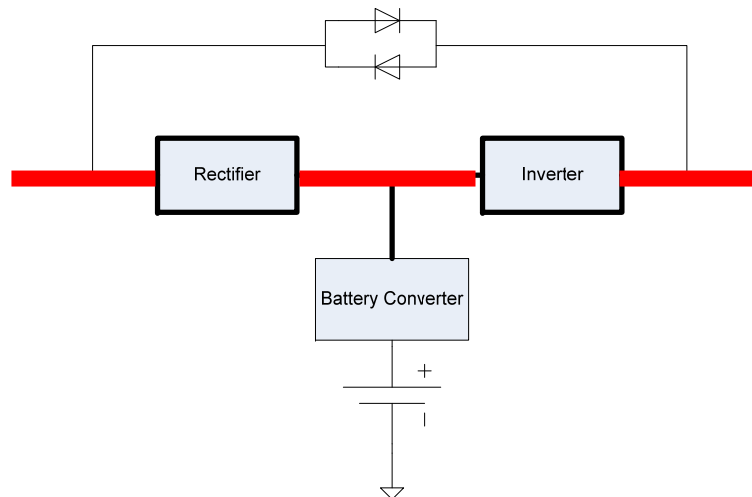

# Feature/Benefit – High-efficiency Multi-mode UPS

---

## High Alert Mode

### Storm Detection

Storm detection is where the 9395 locks into online mode when three power line disturbances has forced three transfers from high efficiency mode to online mode (within a one hour period). The system will then remain in high alert mode for one hour after the last power line disturbance (before transferring back to high efficiency mode). Any power strategy command from the front display will reset the one hour HE mode lockout period.  
Note: One hour timer is EEP configurable

### Optional Predictive Outage Detection

If selected, the optional predictive outage detection will provide a faster transfer time by looking for a delta voltage or frequency. This option will be disabled during generator use.

# Feature/Benefit – PDU-RPP Distribution

- Improved Design
- Greater kVA Availability
- Scalable Architecture
- Enhanced Power Distribution
- Eaton Energy Management System
- Energy Efficient Transformers
- Easier and Safer Accessible
- Spacious Wireways



300kVA PDU

# Feature/Benefit – PDU-RPP Distribution using HE Transformers

Higher Efficiency → Higher Savings  
Does it really make that much a difference?

|                           | Pre-Regulation Transformer | Energy Efficient Transformer | Difference |
|---------------------------|----------------------------|------------------------------|------------|
| Capital Cost              | \$2,000                    | \$3,200                      | \$1,200    |
| Efficiency                | 96.7%                      | 98.0%                        | 1.1%       |
| Annual cost of losses *   | \$1,113                    | \$422                        | \$691      |
| Simple payback (yrs.)     | -                          | 4.09                         | 4.09       |
| Lifetime cost of losses * | \$10,297                   | \$3,985                      | \$6,312    |
| Present value of savings  | -                          | \$1,353                      | -          |

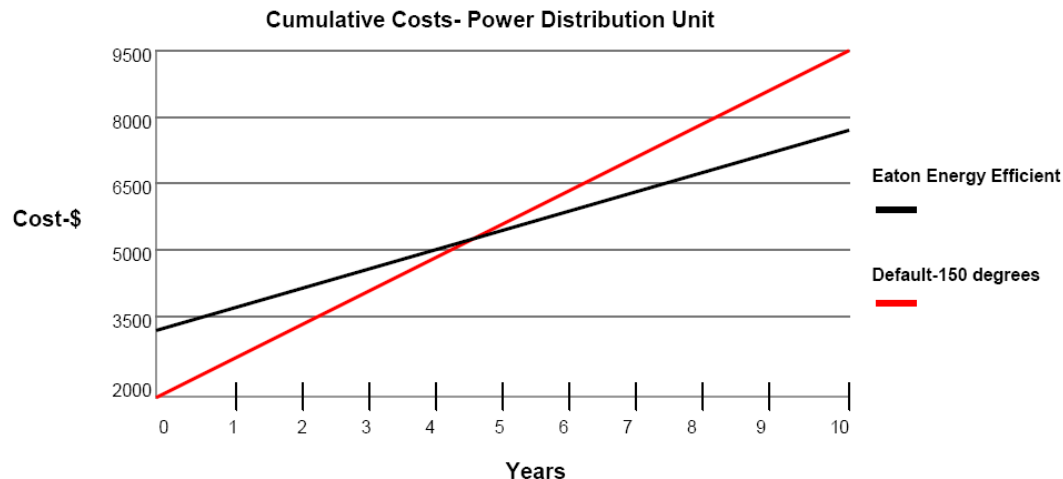

# Feature/Benefit – Remote Power Panels: RPP

- The RPP provides additional power distribution capacity inside your data center closer to the equipment racks.
- Function: Electrical Power Distribution, Equipment Protection, Computer-Grade Grounding and Power Monitoring
- Complete with branch cct monitoring
  - Factory Tested power distribution to ensure highest reliability and consistence
  - Advanced monitoring helps capacity planning and avoid unexpected breaker tripping
  - Allows easy and flexible expansion for your power distribution within a data center



# Feature/Benefit – Remote Power Panels Monitoring

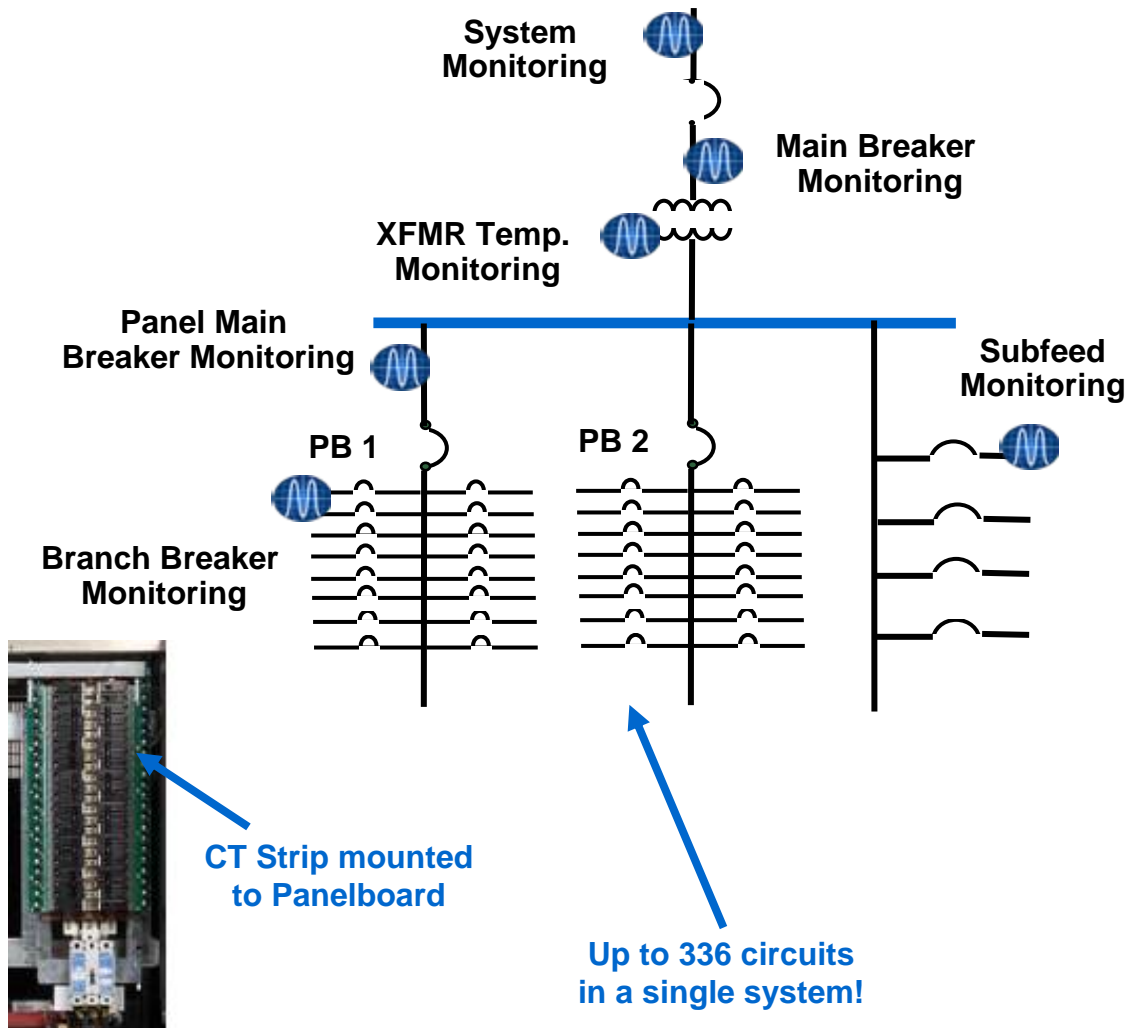

Monitoring on ALL levels!

Universal Controller Board

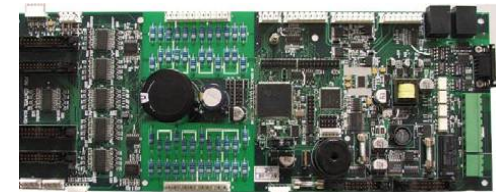

Local Display Information!



CT Strip mounted to Panelboard

# Summary

---

## Footprint

- Available UPS room dimensions were 16 feet by 31 feet. Size of the 9395 UPS/16V battery cabinets provided the minimum floor space required for the necessary 1.5 Megawatts of additional UPS backed power
- PDU/RPP high density design allowed for end of row design, freeing up additional datacenter rack space

## CAPEX/OPEX

- Favorable due to the HE 9395 design
- Efficiency – Based on 7cents KWHR, the true energy savings amounts to over \$27K per year
- PUD Energy rebates from this UPS design are expected to generate nearly \$100K initially

## Monitoring

- RPP branch monitoring give real time data allowing the site to be proactive in maintenance, troubleshooting and predictive diagnostics
- Estimated 20% reduction in CAPEX

**EATON**

*Powering Business Worldwide*